

# 60KM HDMI2.0 Extender Over Fiber

## 4K@60hz YUV4:4:4, HDR

### OPERATION MANUAL



## **Dear Customer**

Thank you for purchasing this product. For optimum performance and safety, please read these instructions carefully before connecting, operating or adjusting this product. Please keep this manual for future reference.

## **TABLE OF CONTENTS**

**Features**

**Package Contents**

**Specifications**

**Panel Descriptions**

**EDID Introduction**

**RS232 Pass Through Function**

**Micro USB Upgrade Firmware**

**Connecting and Operating**

**Typical Application**

**Maintenance**

**Product service**

**Warranty**

## **FEATURES**

- Transmit distance up to 60KM over Single mode, (Multi mode upto 300m) fiber module Single /Duplex fiber (Optional) cable.
- Support resolution upto 4kx2k@60hz, YUV4:4:4 HDR.
- Support bandwidth upto 18Gbps.
- Without latency.
- Support HDCP2.2 input, HDCP2.2 output.
- Support HDCP1.4 input, HDCP1.4 output.
- Support RS232 Bi-direction pass through.
- With Automatic EDID for rapid integration of source and display.
- Support LPCM 7.1, Dolby®True HD, DTS-HD Master Audio™ .
- Locking power supplies.
- Surface-mountable.

### PACKING CONTENTS

- 1). Main Unit. HDMI Extender Over Fiber
- 2). DC12V 1A Power Supply X2
- 3). Operating Instructions

**\*The Unit Without Modules**

### SPECIFICATIONS

|                                   |   |
|-----------------------------------|---|
| Operating Temperature Range       | -5 to +40°C(+23 to +95°F)   |
| Operating Humidity Range          | 5 to 90%RH (No Condensation)  |
| Video Input(Transmitter)          | 1xHDMI Type A, 19-pin, female   |
| Video Output(Receiver)            | 1xHDMI Type A, 19-pin, female   |
| Link(Transmitter/ Receiver)       | 1m~60Km single<br>Multi mode 300m single<br>Duplex fiber optical cable  |
| Module type required <sup>①</sup> | SFP Type, Single / Multi mode ,Single / Duplex fiber (optional)         |
| Video Format                      | 4K@60Hz YUV 4:4:4, 4K@60Hz, 1080P, 720P, 576P, 480P/<br>VESA Resolution |
| Audio Format                      | Support LPCM 7.1, Dolby®True HD, DTS-HD Master Audio™ .                 |
| HDCP                              | HDCP 1.4 in, HDCP 1.4 out<br>HDCP 2.2 in, HDCP 2.2 out                  |
| Power consumption                 | Transmitter: 3watts(Maximum)<br>Receive: 3watts(Maximum)                |
| Dimension (L×W×H)                 | Transmitter: 96*100*21mm<br>Receiver: 96*100*21mm                       |
| Net Weight                        | 475g (Pair)   |

**Note: Specifications are subject to change without notice. Mass and dimensions are approximate.**

**① 4Kx2K requires 10G SFP Transceiver fiber module.**

## PANEL DESCRIPTIONS

### Transmitter Panel

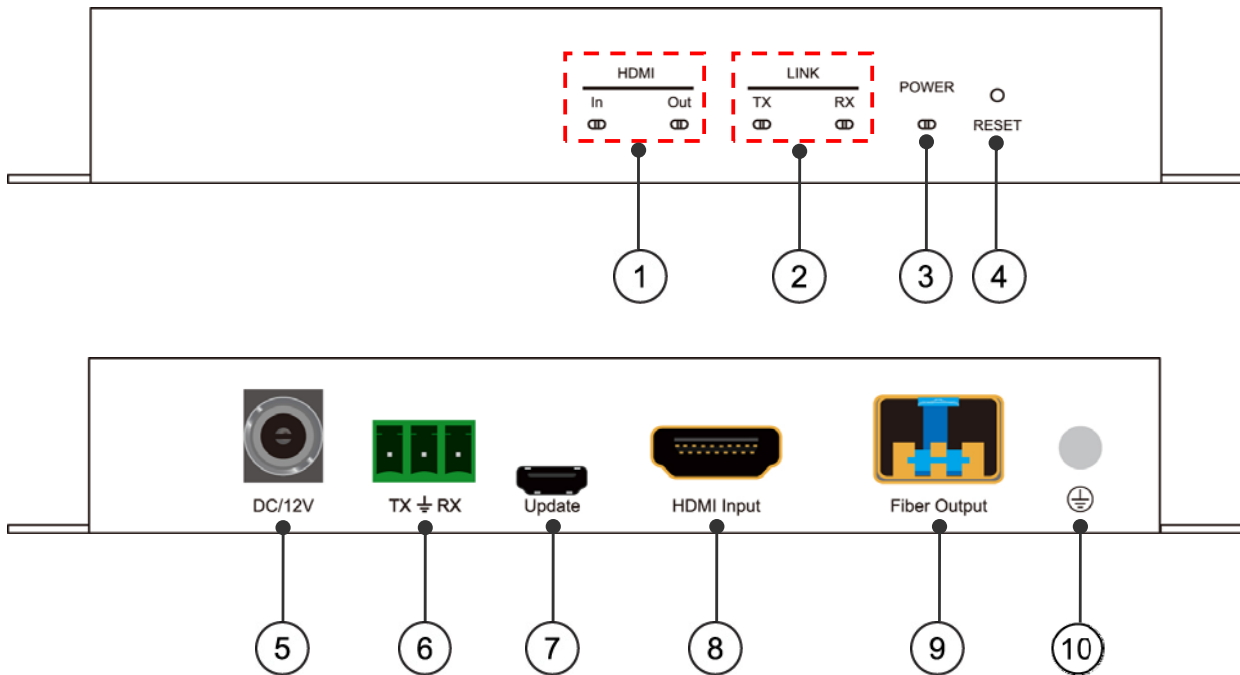

- ① HDMI In/Out indicator
- ② LINK TX/RX indicator
- ③ Power indicator
- ④ EDID Reset
- ⑤ Power input
- ⑥ RS232 input
- ⑦ Upgrade USB port
- ⑧ HDMI input
- ⑨ Fiber output
- ⑩ Grounding

## EDID Introduction

### 1. Automatic EDID

The Automatic EDID function allows automatic copying the EDID from HDMI Display to HDMI source.

### 2. EDID Reset

Step1: Press EDID Reset button for 5 seconds, using the end of a paper clip or other pointed object.

Step2: The indicator of power and status will go out and turn bright again, you have successfully reset the EDID to default status.

Step3: Connect Extender with 4K display.

The default EDID is 1080P, audio 2 channel PCM.

## Receiver Panel

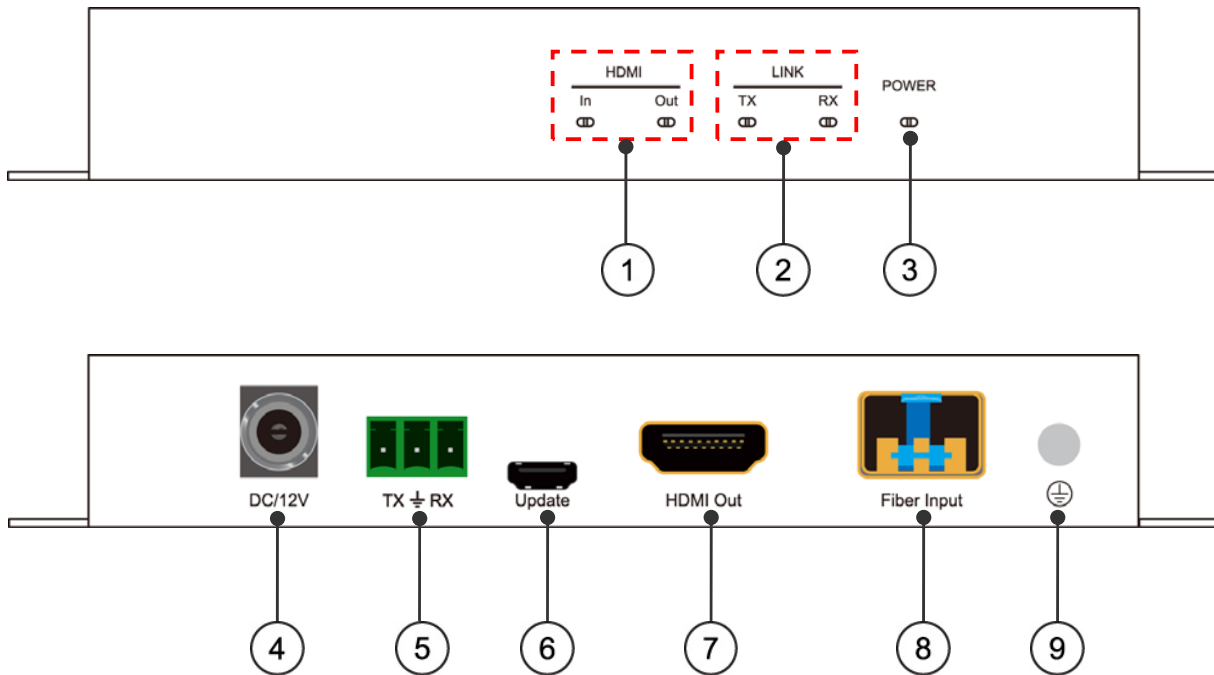

- ① HDMI In/Out indicator
- ② LINK TX/RX indicator
- ③ Power indicator
- ④ Power input
- ⑤ RS232 output
- ⑥ Upgrade USB port
- ⑦ HDMI output
- ⑧ Fiber input
- ⑨ Grounding

### RS232 Pass through function

1. Support Bi-directional transmission by RS232 pass through.
2. The RS232 sender and receiver can be connected with computer or other RS232 device.
3. Default Baud rate: 115200.
4. Band Rate Range.

| Baud rate | Support or not | Baud rate | Support or not |
|-----------|----------------|-----------|----------------|
| 115200    | √              | 14400     | √              |
| 57600     | √              | 9600      | √              |
| 38400     | √              | 4800      | √              |
| 19200     | √              | 2400      | √              |

Support set the baud rate manually.

Setting step: open the serial port interface on the PC (Device Manager), then you can set the baud rate.

## Micro USB Upgrade Firmware

### Operation Step

1. Copy the upgrade files in the PC from the CD.
2. Powered on the Extender.
3. Connect the Extender with the PC via the Micro USB cable via Micro USB Interface.
4. Open the “Device Manager” on the PC, click the “Com”.

We'll see

 **STMicroelectronics Virtual COM Port (COM8)**

Insert port number (P1)

5. Run the upgrade software, as shown in the figure:



Upgrade software icon (P2)

6. Double-click the program upgrade icon and enter the following interface.

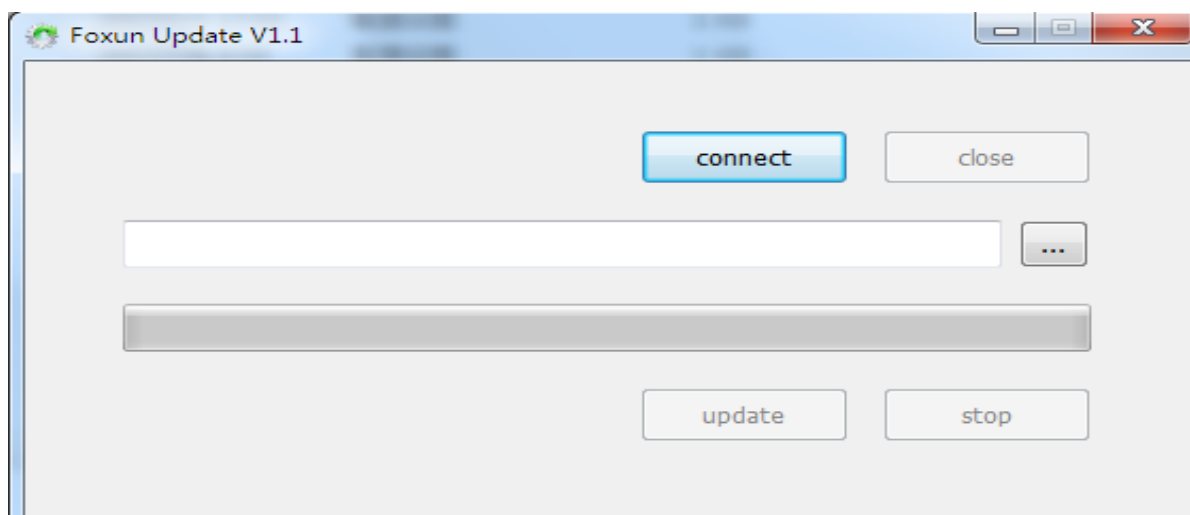

Program upgrade main interface (P3)

## Operating Instructions

---

7. Click “connect” powered off the host Then restart it, the chipset’s specification will show.

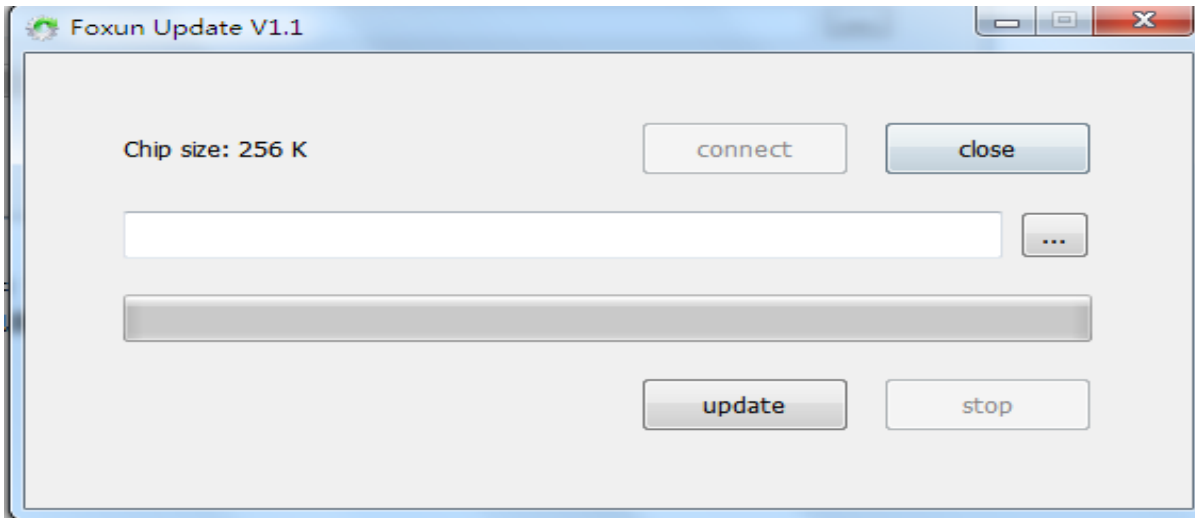

Program upgrade main interface (P4)

8. Click  select the upgrade file to upload.

9. Click “Update”,Then System upgrade.

10. When appear “Update success” dialog box, Program upgrade done.

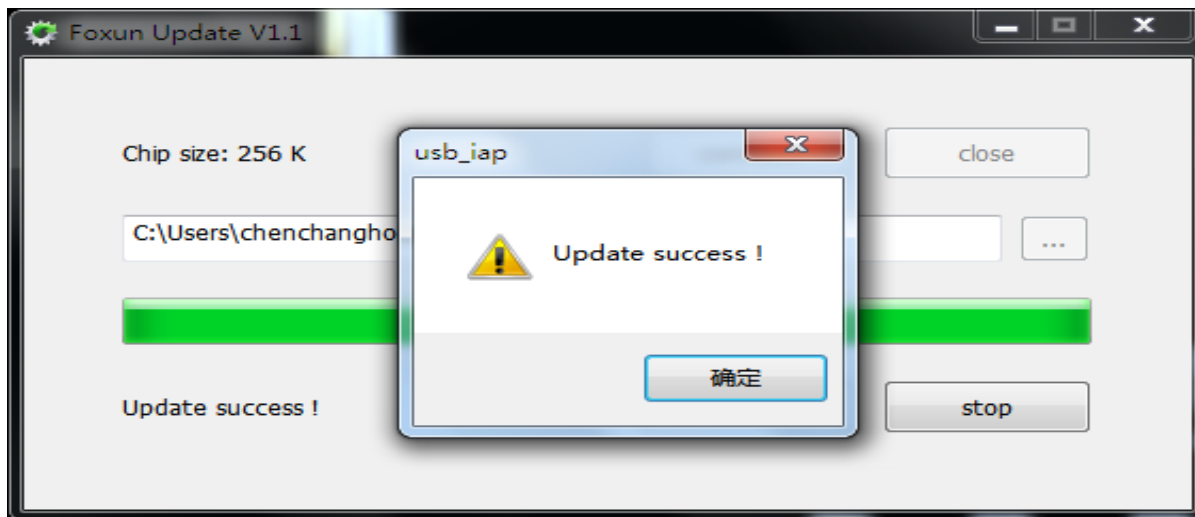

Note: If the connection is upgraded to half current, the upgrade progress bar will stop. At this time, the device should be powered off and restarted before USB upgrade.

### Connecting and Operating

1. Assemble modules with single/multi mode, single/duplex fiber to the HDMI Extender.(4Kx2K requires 10G module)
2. Connect the HDMI input source to input port of the Transmitter of the Fiber Extender by HDMI cable. (Max. 3M for 4K@60Hz, YUV 4:4:4, 8bit-HDR).
3. Connect the duplex fiber optic or Bi-directional single fiber cable to HDMI transmitter and receiver to read the EDID from HDMI Display (Optional).
4. Connect LC-LC single/multi mode single/duplex fiber optic cable between the Fiber port of transmitter and Fiber port of receiver.
5. Connect HDMI display to the HDMI Receiver.
6. Connect RS232 cable with the computer on the Transmitter side.  
Connect RS232 cable with the RS232 device on the Receiver side.
7. Connect the included 12V DC power supplies to the locking power receptacle.
8. Power up the HDMI Extender, sources and displays.

Attention: Insert/Extract cable gently

### Typical Application

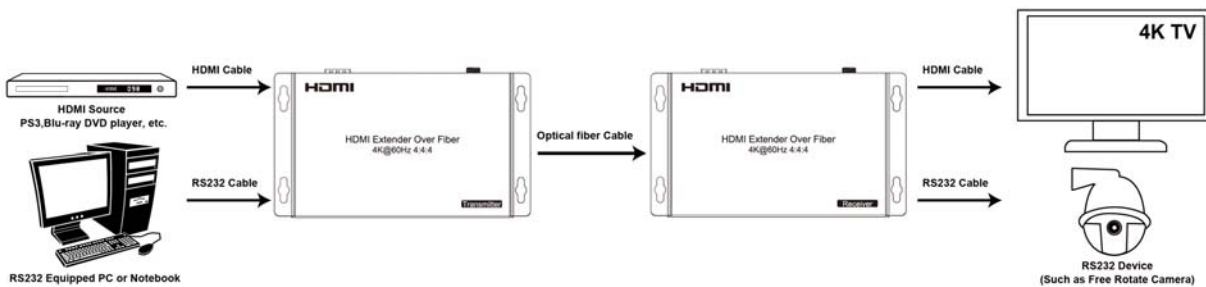



## Operating Instruction

---

### **MAINTENANCE**

Clean this unit with a soft, dry cloth. Never use alcohol, paint thinner or benzene to clean this unit.

### **PRODUCT SERVICE**

**1) Damage requiring service:** The unit should be serviced by qualified service personnel if:

- The DC power supply cord or AC adaptor has been damaged;
- Objects or liquids have gotten into the unit;
- The unit has been exposed to rain;
- The unit does not operate normally or exhibits a marked change in performance;
- The unit has been dropped or the cabinet damaged.

**2) Servicing Personnel:** Do not attempt to service the unit beyond that described in these operating instructions. Refer all other servicing to authorized servicing personnel.

**3) Replacement parts:** When parts need replacing ensure the servicer uses parts specified by the manufacturer or parts that have the same characteristics as the original parts. Unauthorized substitutes may result in fire, electric shock, or other hazards.

**4) Safety check:** After repairs or service, ask the servicer to perform safety checks to confirm that the unit is in proper working condition.

### **WARRANTY**

If your product does not work properly because of a defect in materials or workmanship, our Company (referred to as "the warrantor" ) will , for the length of the period indicated as below, **(Parts(2)Year ,Labor(90) Days)** which starts with the date of original purchase ("Limited Warranty period"), at its option either(a) repair your product with new or refurbished parts, or (b) replace it with a new or a refurbished product. The decision to repair or replace will be made by the warrantor.

During the "Labor" Limited Warranty period there will be no charge for labor.

During the "Parts" warranty period, there will be no charge for parts. You must mail-in your product during the warranty period. This Limited Warranty is extended only to the original purchaser and only covers product purchased as new. A purchase receipt or other proof of original purchase date is required for Limited Warranty service.

### **Mail-In Service**

When shipping the unit carefully pack and send it prepaid, adequately insured and preferably in the original carton. Include a letter detailing the complaint and provide a day time phone and/or email address where you can be reached.

### **LIMITED WARRANTY LIMITS AND EXCLUSIONS**

1) This Limited Warranty ONLY COVERS failures due to defects in materials or workmanship, and DOES NOT COVER normal wear and tear or cosmetic damage. The Limited Warranty ALSO DOES NOT COVER damages which occurred in shipment, or failures which are caused by products not supplied by warrantor, or failures which result from accidents, misuse, abuse, neglect, mishandling, misapplication, alteration, faulty installation, set-up adjustments, maladjustment of consumer controls, improper maintenance, power line surge, lightning damage, modification, or service by anyone other than a Factory Service center or other Authorized Servicer, or damage that is attributable to acts of God.

2) THERE ARE NO EXPRESS WARRANTIES EXCEPT AS LISTED UNDER "LIMITED WARRANTY COVERAGE". THE WARRANTOR IS NOT LIABLE FOR INCIDENTAL OR CONSEQUENTIAL DAMAGES RESULTING FROM THE USE OF THIS PRODUCT, OR ARISING OUT OF ANY BREACH OF THIS WARRANTY. (As examples, this excludes damages for lost time, cost of having someone remove or re-install an installed unit if applicable, travel to and from the service, loss of or damage to media or images, data or other recorded content. The items listed are not exclusive, but are for illustration only.)

3) PARTS AND SERVICE, WHICH ARE NOT COVERED BY THIS LIMITED WARRANTY, ARE YOUR RESPONSIBILITY.