

1X2 Splitter / 2x1 Switch

4K@60hz YUV4:4:4 18Gbps

Support HDCP2.2, HDR10

/// OPERATION MANUAL



Dear customer

Thank you for purchasing this product. For optimum performance and safety, please read these instructions carefully before connecting, operating or adjusting this product. Please keep this manual for future reference.

TABLE OF CONTENTS

Features

Specifications

Package Contents

Panel Description

Application

Remote Control Description

Maintenance

Product Service

Warranty

Features

- HDMI 2.0 version (Support 4K@60Hz YUV4:4:4)
- Bandwidth upto 18Gbps
- HDCP2.2/ HDCP1.4
- Support HDR10,Dolby vision
- Support 2xHDMI in, 2xHDMI out
- Support EDID copy
- Micro USB interface for user to upgrade firmware
- Low power consumption(2W max), 5V input

Specifications

Operating Temperature Range	0°C to +40°C (+32°F to +104°F)
Operating Humidity Range	5 to 90%RH (No Condensation)
Power supply	5V
Maximum power (work under 4K2K/60hz)	358mA
Max resolution	4k@60hz YUV4:4:4
Function	HDR10 and Dolby vision
HDMI version	HDMI 2.0
HDCP version	HDCP2.2 / HDCP1.4(Auto choose depend on TV version)
Control ways	Switch button and EDID
Distance	1080P: input 8m max; output 15m max 4k@30hz: input 8m max;output 15m max 4k@60hz-8bit: input 5m max;output 5m max
Dimensions(LxWxH)	71.7x52x12mm

Package Contents

- 1) 1x HDMI Switch
- 2) 1x 5V/1A DC power adapter
- 3) 1x USB cable
- 4) 1x User manual

Panel Description

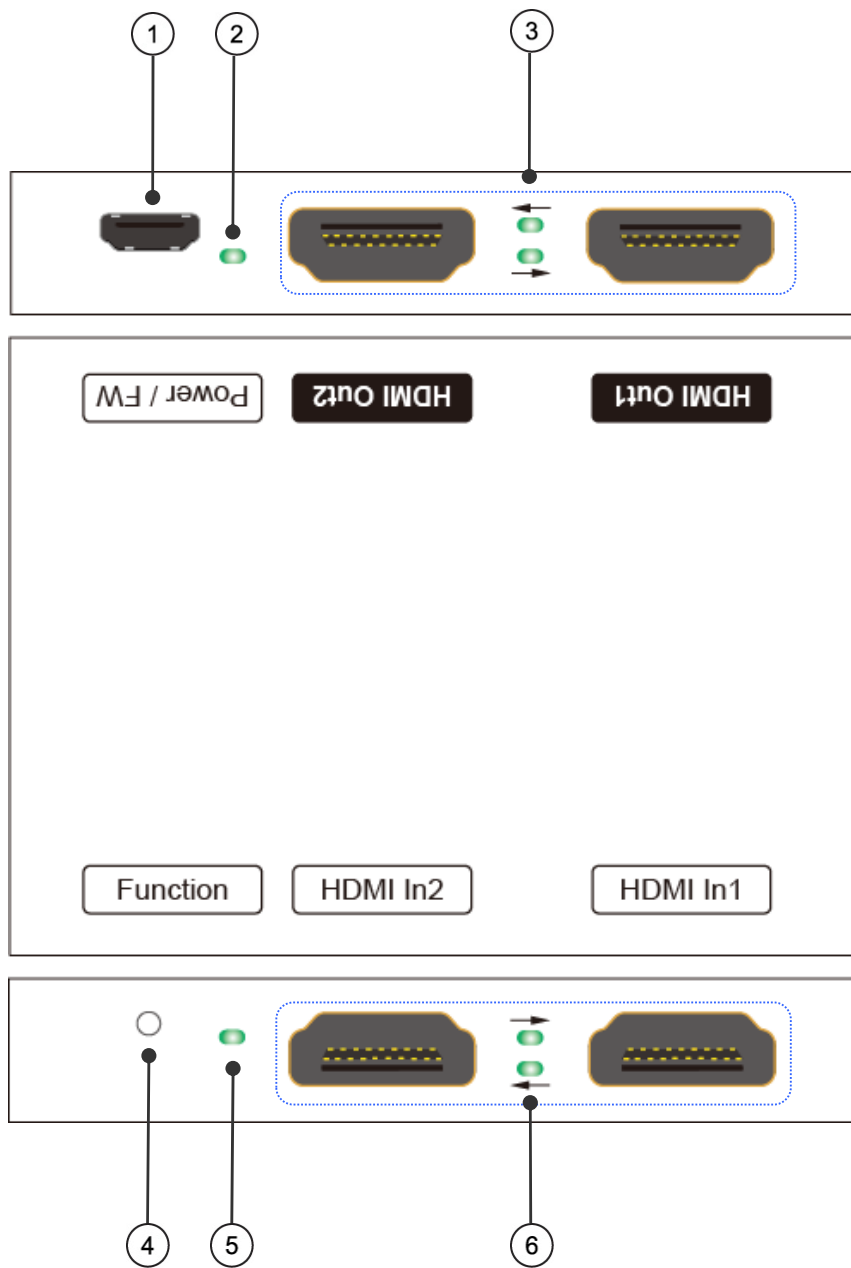

- ① Power and Firmware upgrade USB port
- ② Power Indicator
- ③ HDMI Output Indicator
- ④ Function button
- ⑤ EDID Indicator
- ⑥ HDMI Input Indicator

Application

1. Connect source devices with input ports of the switch by HDMI Cable.
2. Connect HDMI output port with TV or other HDMI sink devices by HDMI Cable.
3. Connect 5V POWER adaptor with DC power socket.
4. Power on

Application Diagram

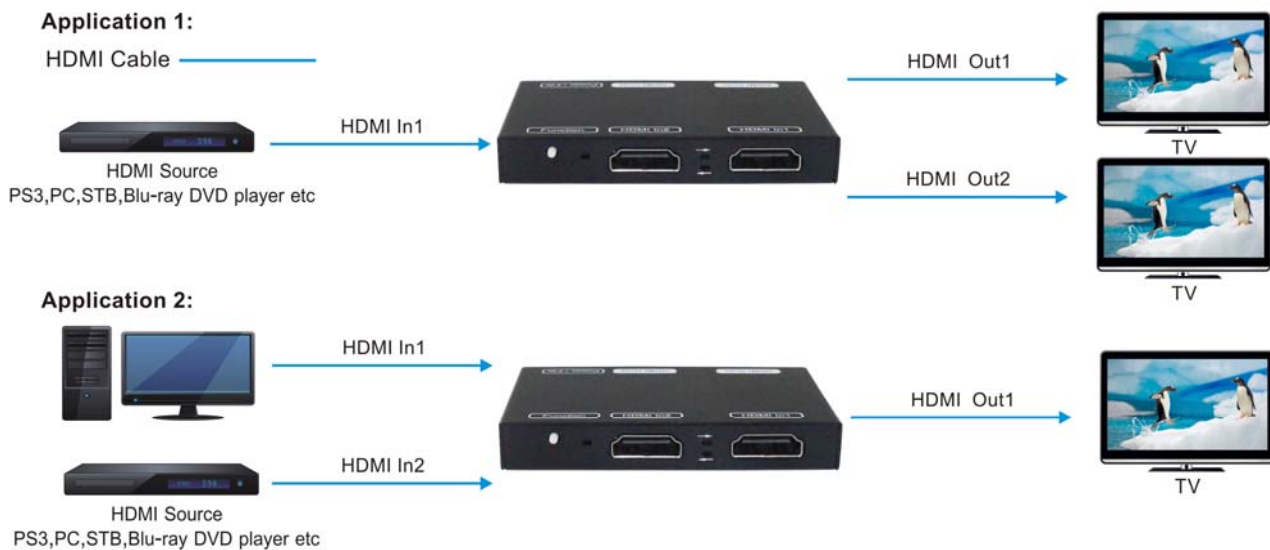

MAINTENANCE

Clean this unit with a soft, dry cloth. Never use alcohol, paint thinner or benzene to clean this unit.

PRODUCT SERVICE

- 1) Damage requiring service:** The unit should be serviced by qualified service personnel if:
- (a) The DC power supply cord or AC adaptor has been damaged;
 - (b) Objects or liquids have gotten into the unit;
 - (c) The unit has been exposed to rain;
 - (d) The unit does not operate normally or exhibits a marked change in performance;
 - (e) The unit has been dropped or the cabinet damaged.

WARRANTY

If your product does not work properly because of a defect in materials or workmanship, our Company (referred to as "the warrantor") will , for the length of the period indicated as below, **(Parts(2)Year ,Labor(90) Days)** which starts with the date of original purchase ("Limited Warranty period"), at its option either(a) repair your product with new or refurbished parts, or (b) replace it with a new of a refurbished product. The decision to repair or replace will be made by the warrantor.

During the "Labor" Limited Warranty period there will be no charge for labor.

During the "Parts" warranty period, there will be no charge for parts. You must mail-in your product during the warranty period. This Limited Warranty is extended only to the original purchaser and only covers product purchased as new. A purchase receipt or other proof of original purchase date is required for Limited Warranty service.

Mail-In Service

When shipping the unit carefully pack and send it prepaid, adequately insured and preferably in the original carton. Include a letter detailing the complaint and provide a day time phone and/or email address where you can be reached.

LIMITED WARRANTY LIMITS AND EXCLUSIONS

1) This Limited Warranty ONLY COVERS failures due to defects in materials or workmanship, and DOES NOT COVER normal wear and tear or cosmetic damage. The Limited Warranty ALSO DOES NOT COVER damages which occurred in shipment, or failures which are caused by products not supplied by warrantor, or failures which result from accidents, misuse, abuse, neglect, mishandling, misapplication, alteration, faulty installation, set-up adjustments, maladjustment of consumer controls, improper maintenance, power line surge, lightning damage, modification, or service by anyone other than a Factory Service center or other Authorized Servicer, or damage that is attributable to acts of God.

2) THERE ARE NO EXPRESS WARRANTIES EXCEPT AS LISTED UNDER "LIMITED WARRANTY COVERAGE". THE WARRANTOR IS NOT LIABLE FOR INCIDENTAL OR CONSEQUENTIAL DAMAGES RESULTING FROM THE USE OF THIS PRODUCT, OR ARISING OUT OF ANY BREACH OF THIS WARRANTY. (As examples, this excludes damages for lost time, cost of having someone remove or re-install an installed unit if applicable, travel to and from the service, loss of or damage to media or images, data or other recorded content. The items listed are not exclusive, but are for illustration only.)

3) PARTS AND SERVICE, WHICH ARE NOT COVERED BY THIS LIMITED WARRANTY, ARE YOUR RESPONSIBILITY.